



Troubleshooting Guide

Model 478DA (D-15)

Single Intercom System

Introduction

The Model 478DA is a single-channel intercom system that is used for point-to-point communication applications. The system includes a visible/audible presence alert and the capability of multiple units communicating with the same loudspeaker.

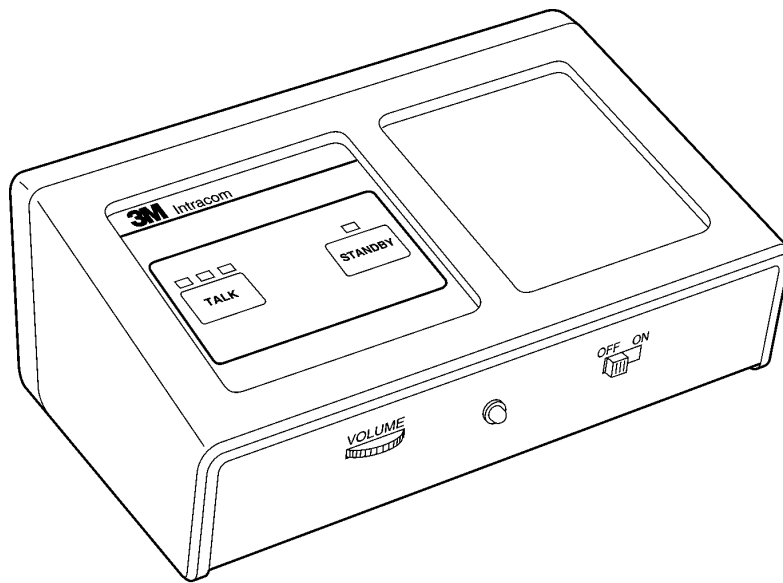

SP-211A

Problem Isolation Procedure

Use the troubleshooting table on the following pages to help isolate the problem:

1. Start at the top of the table and work down to the bottom.
2. For each symptom listed, determine if it applies to the situation.
3. If a symptom **does** apply, check (✓) the box adjacent to the symptom.
4. Read across the table to the possible causes and corrections listed in the middle and right columns.
5. Investigate these possible causes and implement the corrections. Possible causes are listed in the order in which they are most likely to occur.

If none of the possible causes and corrections applies to the situation, call 3M Media InTouch and review the "checked" symptoms with the technical support staff.

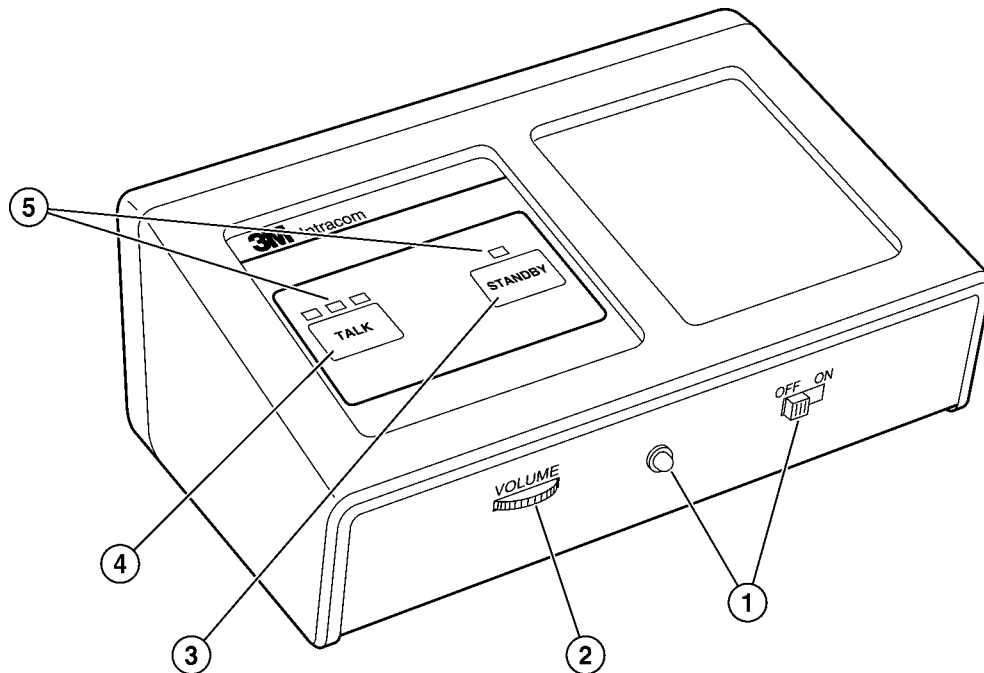

SP-212A

Figure 1. Operating Controls

Key	Control Name	Function
1	Power Switch	Controls application of power to the system.
	Power Indicator Light	Indicates power is applied to the system.
2	Volume Control	Adjusts the internal speaker (listen) audio level.
3	Standby Touch Switch	Silences intercom audio to eliminate pickup of undesired background noise and reconnects optional music/message source to the external speaker when unit is not in use. The system automatically exits the standby mode with vehicle detection or when the Touch/Talk switch is pressed.
4	Touch/Talk Switch	Controls talk/listen communications. Operator touches switch to talk and cancel alert tone. Operator releases switch to listen.
5	Indicator Lights	Red indicates TALK mode. Green indicates LISTEN mode. Yellow indicates vehicle presence. Yellow light above STANDBY lights and all other lights are extinguished when the system is placed in the standby mode.

Troubleshooting Table

Problem		Possible Cause	Correction
	No inbound audio. Power Indicator Light (green) is OFF.	No AC power to the unit.	Check power supply transformer or wall outlet.
		Defective analog board.	Check and replace analog board.
	No inbound audio: <ul style="list-style-type: none"> • Power Indicator Light (green) is ON. • LISTEN Indicator Light (green) is OFF. 	Defective logic board or touch pad.	Check and replace logic board or touch pad.
	No inbound audio: <ul style="list-style-type: none"> • Power Indicator Light (green) is ON. • LISTEN Indicator Light (green) is ON. 	Defective menu speaker, menu mic, or wiring.	Check and replace menu speaker, menu mic, or wiring.
		Defective analog board.	Check and replace analog board.
	Inbound audio distorted.	Defective menu speaker, menu mic, or wiring.	Check and replace menu speaker, menu mic, or wiring.
		Defective analog board.	Check and replace analog board.
	No outbound audio. Power Indicator Light (green) is OFF.	No AC power to the unit.	Check power supply transformer or wall outlet.
		Defective analog board.	Check and replace analog board.
	No outbound audio: <ul style="list-style-type: none"> • Power Indicator Light (green) is ON. • TALK Indicator Light (red) is OFF when TALK SWITCH is pressed. 	Defective logic board or touch pad.	Check and replace logic board or touch pad.

(continued)

Problem	Possible Cause	Correction
No outbound audio: <ul style="list-style-type: none"> • Power Indicator Light (green) is ON. • TALK Indicator Light (red) is ON when TALK SWITCH is pressed. 	Defective menu speaker, menu mic, or wiring.	Check and replace menu speaker, menu mic, or wiring.
	Defective analog board.	Check and replace analog board.
With car on loop, VEHICLE Indicator Light (yellow) is ON, but vehicle detection tone does not sound.	Alert volume control setting too low.	Check and/or increase the Alert volume control setting on bottom of unit.
	Defective analog board.	Check and replace analog board.
With car on loop, VEHICLE Indicator Light (yellow) is OFF, and vehicle detection tone does not sound.	Defective logic or analog board.	Check and replace logic or analog board.
Outbound audio distorted.	Defective analog board.	Check and replace analog board.
	Defective internal microphone.	Replace microphone.
	Defective menu sign speaker.	Replace menu sign speaker.



Troubleshooting Guide

Model 481 BA (D-20) 6-Channel Intercom System

Introduction

The Model 481 is a 6-channel intercom system that is typically used to provide communication between store counters and pump islands in self-service gas stations, convenience stores and truck stops.

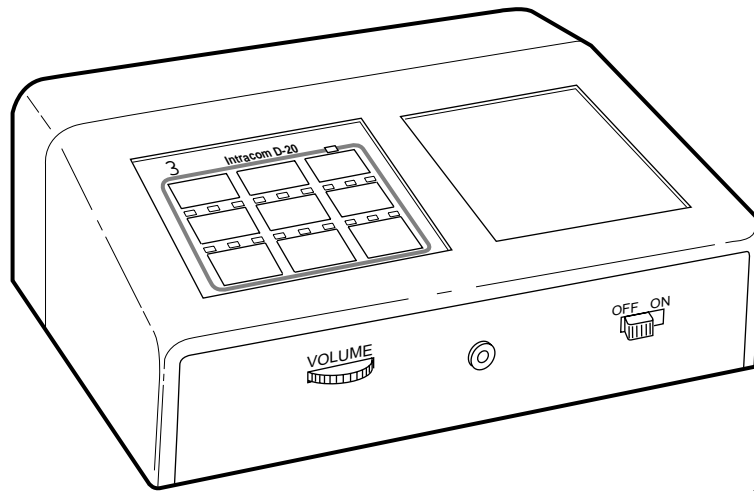

SP-206A

Problem Isolation Procedure

Use the troubleshooting table on the following pages to help isolate the problem:

1. Start at the top of the table and work down to the bottom.
2. For each symptom listed, determine if it applies to the situation.
3. If a symptom **does** apply, check (✓) the box adjacent to the symptom.
4. Read across the table to the possible causes and corrections listed in the middle and right columns.
5. Investigate these possible causes and implement the corrections. Possible causes are listed in the order in which they are most likely to occur.

If none of the possible causes and corrections applies to the situation, call 3M Media InTouch and review the "checked" symptoms with the technical support staff.

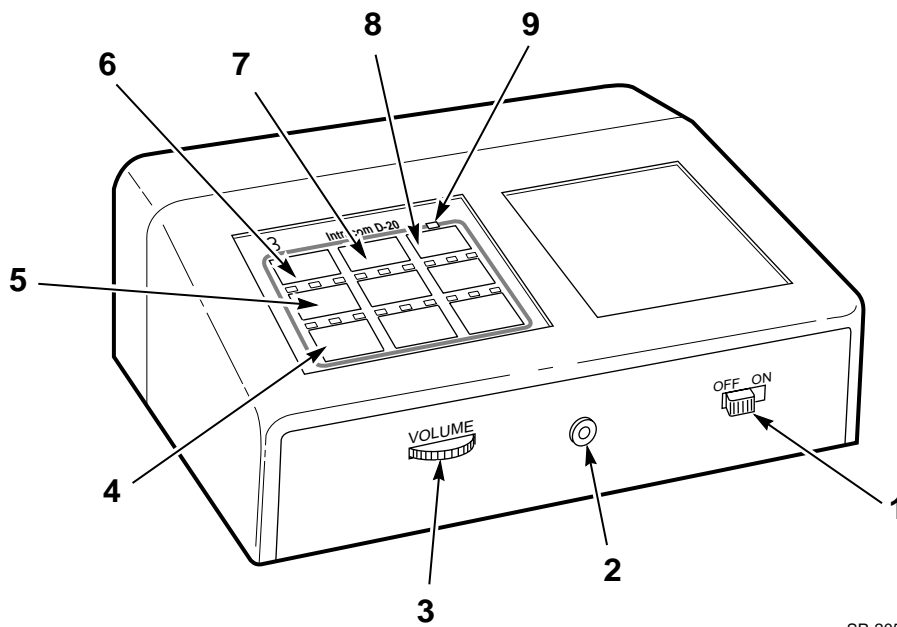

SP-205A

Figure 1. Operating Controls

Key	Control Name	Function
1	Power Switch	Provides power to mainstation.
2	Power Indicator Light	Indicates power is on and the system is ready to operate.
3	Volume Control	Adjusts INCOMING audio level. NOTE: Volume level adjustments for alert tone and outside speakers are set by the installer.
4	Channel Selector Switches (1-6)	These switches control talk/listen communication for numbered channels. Operator touches switch to talk and releases switch to listen.
5	Indicator Lights	Red indicates TALK mode. Green indicates LISTEN mode. Yellow (steady) indicates channel on "HOLD." Yellow (flashing) indicates incoming call WAITING.
6	Hold Switch	Places selected channel in "HOLD" mode.
7	All Call Switch	Controls conversation with all channels simultaneously.
8	Standby Switch	Silences incoming audio to eliminate undesired background noise pickup when unit is not in use. Touching any CHANNEL SELECTOR SWITCH releases STANDBY mode.
9	Standby Indicator Light	Indicates unit is in STANDBY mode.

Troubleshooting Table

Problem	Possible Cause	Correction
No inbound audio. Power Indicator Light (green) is OFF.	No AC power to the unit.	Check power supply transformer or wall outlet.
No inbound audio: <ul style="list-style-type: none"> • Power Indicator Light (green) is ON. • LISTEN Indicator Light (green) is OFF. 	Defective logic board or touch pad.	Check and replace logic board or touch pad.
No inbound audio: <ul style="list-style-type: none"> • Power Indicator Light (green) is ON. • LISTEN Indicator Light (green) is ON. 	Defective speaker/mic or analog board.	Check and replace speaker or analog board.
Inbound audio distorted.	Defective speaker/mic or analog board.	Check and replace speaker/mic or analog board.
No outbound audio: <ul style="list-style-type: none"> • Power Indicator Light (green) is ON. • TALK Indicator Light (red) is OFF when TALK SWITCH is pressed. 	Defective logic board or touch pad.	Check and replace logic board or touch pad.
No outbound audio: <ul style="list-style-type: none"> • Power Indicator Light (green) is ON. • TALK Indicator Light (red) is ON when TALK SWITCH is pressed. 	Defective speaker/mic or analog board.	Check and replace speaker/mic or analog board.
The VEHICLE Indicator Light (yellow) blinks, but vehicle detection tone does not sound.	Alert volume too low.	Check and adjust alert volume control on analog board.
	Defective analog or logic board.	Check and replace analog or logic board.

(Continued)

Problem	Possible Cause	Correction
The VEHICLE Indicator Light (yellow) is OFF and the vehicle detection tone does not sound.	Defective call switch.	Check and replace call switch.
	Defective analog or logic board.	Check and replace analog or logic board.
Unit will not return to standby mode when STANDBY Switch is pressed.	Defective logic board.	Check and replace logic board.
Unit will not come out of standby mode.	Defective logic board.	Check and replace logic board.
Outbound audio distorted.	Defective analog board.	Check and replace analog board.
	Defective internal microphone.	Replace microphone.
	Defective outside speaker.	Replace speaker.



Troubleshooting Guide

Model 479 (D-30) 2-Channel Intercom System

Introduction

The Model 479 is a 2-channel intercom system that is typically used to provide communication between store counters and pump islands in self-service gas stations, convenience stores and truck stops.

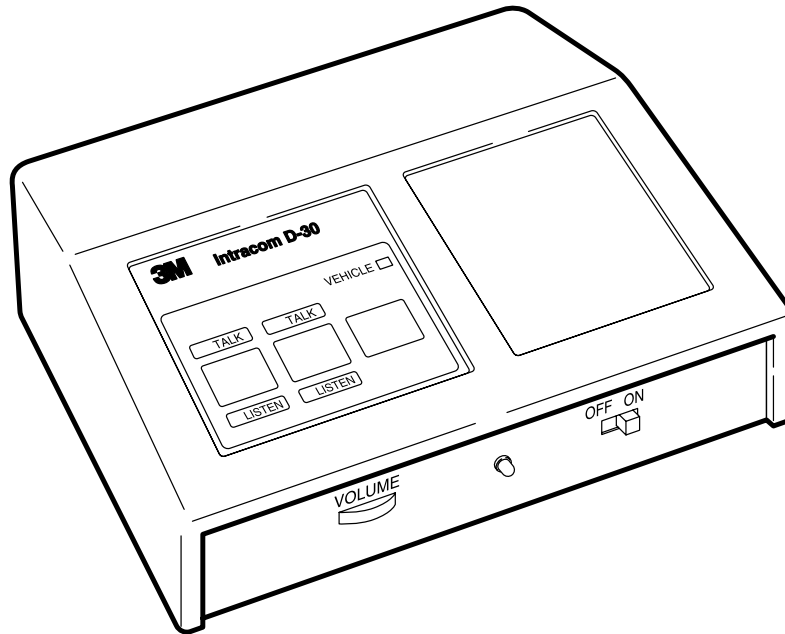

Problem Isolation Procedure

Use the troubleshooting table on the following pages to help isolate the problem:

1. Start at the top of the table and work down to the bottom.
2. For each symptom listed, determine if it applies to the situation.
3. If a symptom **does** apply, check (✓) the box adjacent to the symptom.
4. Read across the table to the possible causes and corrections listed in the middle and right columns.
5. Investigate these possible causes and implement the corrections. Possible causes are listed in the order in which they are most likely to occur.

If none of the possible causes and corrections applies to the situation, call 3M Media InTouch and review the "checked" symptoms with the technical support staff.

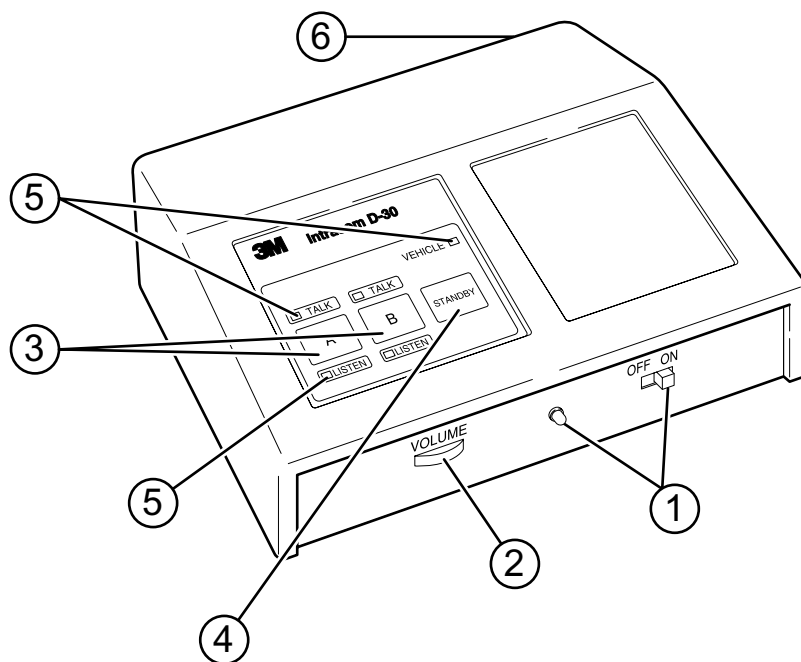

SP-208A

Figure 1. Operating Controls

Key	Control Name	Function
1	Power Switch	Controls application of power to the system.
	Power Indicator Light	Indicates power is applied to the system.
2	Volume Control	Adjusts the mainstation internal speaker (listen) audio level.
3	Talk Switches (A & B)	Control talk/listen communication for the respective channel (A or B). Operator touches switch to talk and releases switch to listen.
4	Standby Switch	Silences audio to eliminate pickup of undesired background noise when unit is not in use. Touching either the Channel A or Channel B Talk Switch releases STANDBY mode. Vehicle Detection automatically places the system into the Channel A listen mode.
5	Indicator Lights (same for Channel A and Channel B)	Red indicates TALK mode. Green indicates LISTEN mode. Yellow indicates vehicle presence (when used with 3M SODAR or magnetic loop detection system). All indicator lights are extinguished when mainstation is in the standby mode.
6	Standby Mode Switch	AUTO (automatic) position causes system to switch from Channel A Listen to Standby when there is no vehicle detect signal. MAN (manual) position allows operator to use Channel A without vehicle detection.

Troubleshooting Table

Problem	Possible Cause	Correction
No inbound audio. Power Indicator Light (green) is OFF.	No AC power to the unit.	Check power supply transformer or wall outlet.
	Defective analog board.	Check and replace analog board.
No inbound audio: <ul style="list-style-type: none"> • Power Indicator Light (green) is ON. • LISTEN Indicator Light (green) is OFF. 	Defective logic board or touch pad.	Check and replace logic board or touch pad.
No inbound audio: <ul style="list-style-type: none"> • Power Indicator Light (green) is ON. • LISTEN Indicator Light (green) is ON. 	Defective menu speaker, menu mic, or wiring.	Check and replace menu speaker, menu mic, or wiring.
	Defective analog board.	Check and replace analog board.
Inbound audio distorted.	Defective menu speaker, menu mic, or wiring.	Check and replace menu speaker, menu mic, or wiring.
	Defective analog board.	Check and replace analog board.
No outbound audio. Power Indicator Light (green) is OFF.	No AC power to the unit.	Check power supply transformer or wall outlet.
	Defective analog board.	Check and replace analog board.
No outbound audio: <ul style="list-style-type: none"> • Power Indicator Light (green) is ON. • TALK Indicator Light (red) is OFF when TALK SWITCH is pressed. 	Defective logic board or touch pad.	Check and replace logic board or touch pad.

(continued)

Problem	Possible Cause	Correction
No outbound audio: <ul style="list-style-type: none"> • Power Indicator Light (green) is ON. • TALK Indicator Light (red) is ON when TALK SWITCH is pressed. 	Defective menu speaker, menu mic, or wiring.	Check and replace menu speaker, menu mic, or wiring.
	Defective analog board.	Check and replace analog board.
With car on loop, VEHICLE Indicator Light (yellow) is ON, but vehicle detection tone does not sound.	Vehicle Detect-to-Main signal too low.	Adjust R6 to increase signal level.
	Defective analog board.	Check and replace analog board.
With car on loop, VEHICLE Indicator Light (yellow) is OFF, and vehicle detection tone does not sound.	Defective logic or analog board.	Check and replace logic or analog board.
Outbound audio distorted.	Defective analog board.	Check and replace analog board.
	Defective internal microphone.	Replace microphone.
	Defective menu sign speaker.	Replace menu sign speaker.